

Lionel® Line Pedal Train OWNER'S MANUAL

[Please keep this Owner's Manual for future reference. If you sell or give this product to someone, please include this Owner's Manual, and ask the new owners to read the instructions completely before operating.]

Congratulations for choosing your new Lionel® Line Pedal Train. We have carefully constructed your Lionel Line Pedal Train so that its safety and performance meet the highest standards. Make sure the size of the Pedal Train meets your child's personal requirements and Pedal Train is assembled and adjusted by an adult. With proper care and maintenance, your new Pedal Train will give your child riding pleasure for years to come.

Some illustrations may vary from actual Pedal Train as delivered. If you have any questions after reading this manual, please contact one of our Customer Service Representatives by Email help@morgancycle.com or (973) 960-2688.

PRIOR TO ASSEMBLY:

- Please read this Owner's Manual completely before assembling or operating this product.
- Assembly of this product should be carried out by an adult.
- All parts are Wrapped in PACKING MATERIAL to prevent damage during shipment. Remove all packing materials from the box prior to assembly. Save all packing materials until assembly is complete to make sure no parts are accidentally thrown away. After assembly is complete, properly discard all waste.
- Refer to the Parts List and Diagram on page two of this manual to make sure all parts is accounted for.
- **DO NOT RETURN** this product to the store! If any parts are missing or damaged, please contact one of our Customer Service Representatives by e-mail: help@morgancycle.com or **(973)-960-2688**.

This is how your new Lionel® Line Pedal Train should look when assembly completed.

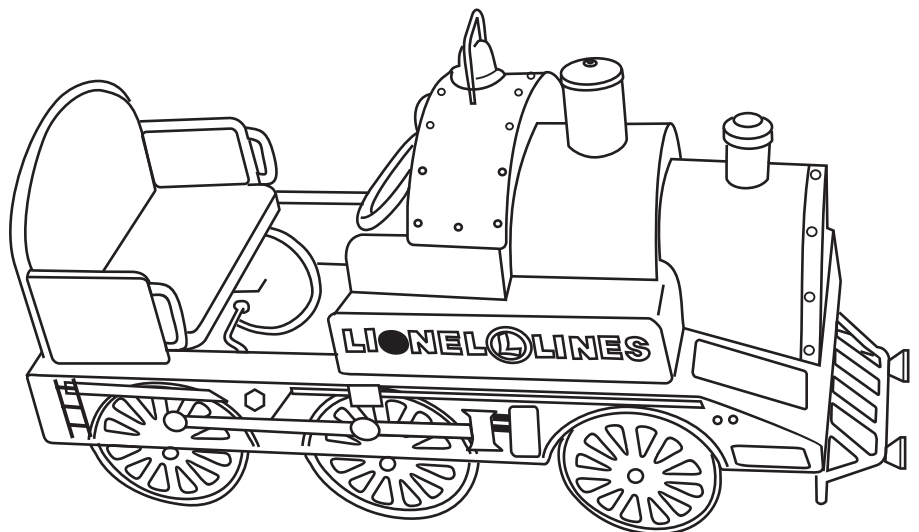
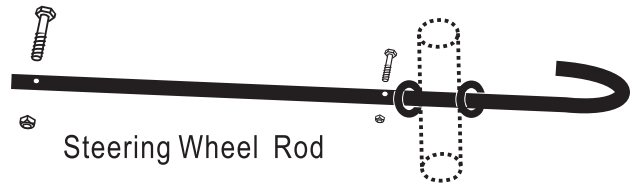
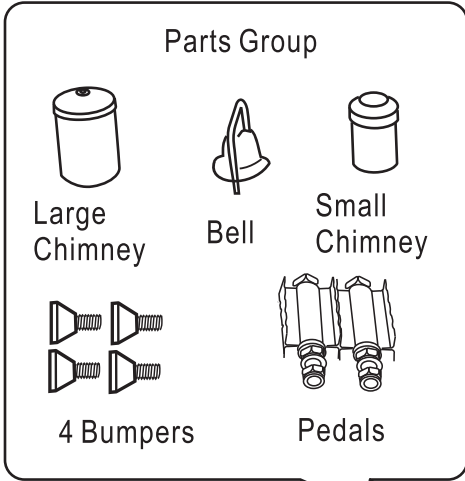
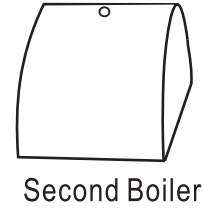
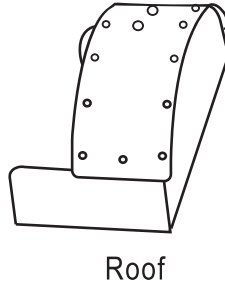
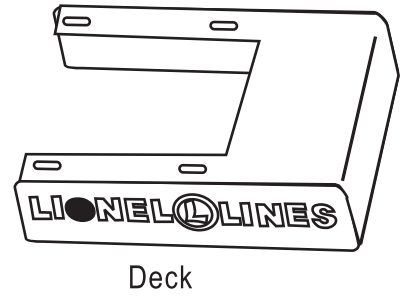

Figure 1



Parts List

- 1 Parts Group
- 1 Steering Wheel
- 1 Steering Wheel Rod
- 1 Seat Pads Set
- 1 Train Frame.
- 1 Seat Back
- 1 Rear Deck
- 1 Deck.
- 1 Front Boiler
- 1 Second Boiler
- 1 Cowcatcher Support Rod
- 1 Cowcatcher
- 1 Roof
- 1 Sound Box

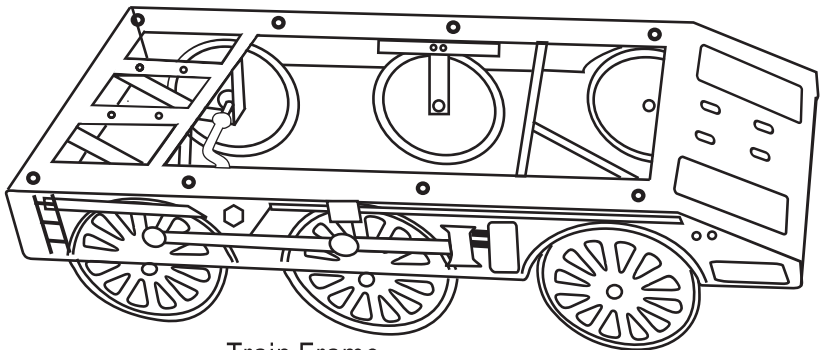
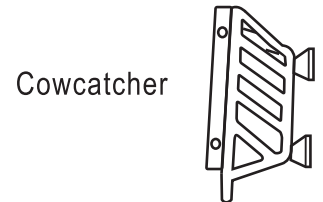
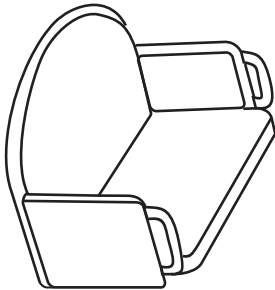
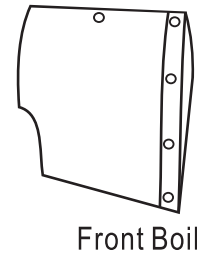

Figure 2

TOOLS REQUIRED FOR ASSEMBLY:

- 10 - 16 mm Wrench
- Adjustable Wrench
- Screw Driver

Follow the Six Step instructions below, in order from 1 to 6,
 Assembly of this product should be carried out by an adult.

Step 1 (As shown at Figure 3)

- 1) Screw the Bell on the Roof.
- 2) Screw the Large Chimney onto the Second Boiler.
- 3) Screw the Small Chimney onto the Front Boiler.

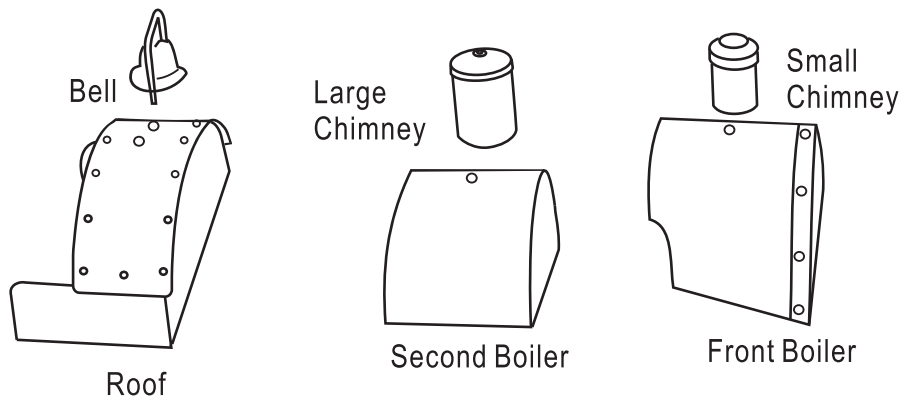

Figure 3

Step 2 (As shown at Figure 4)

- 1) Lay a piece of soft Rag on the Table to protect train from scratches..
- 2) Put the Train Frame on the Table.

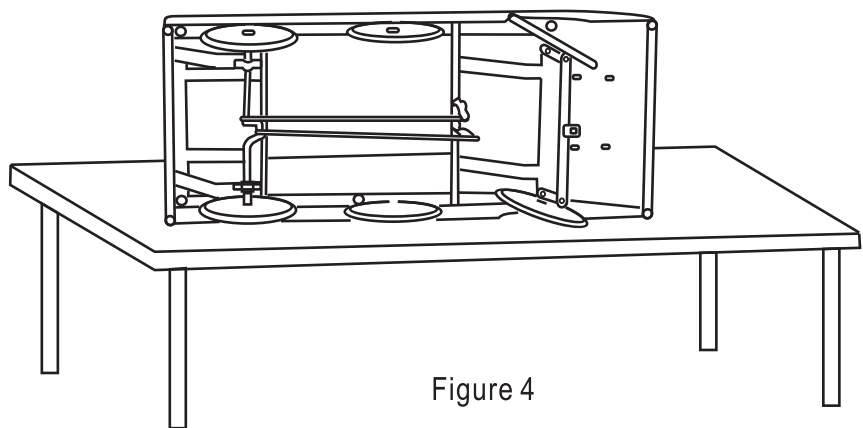

Figure 4

Step 3 (As shown at Figure 5)

- 1) Use 10 mm wrench to secure the Seat Back and Deck onto the Train Frame.
- 2) Secure the Front Boiler onto the Train Frame.
- 3) Secure the Seat Pad on the Train Frame. And put the Seat Pads on the Seat Back.

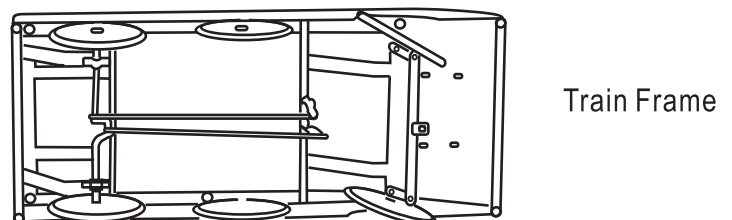
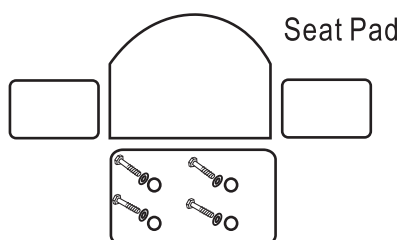
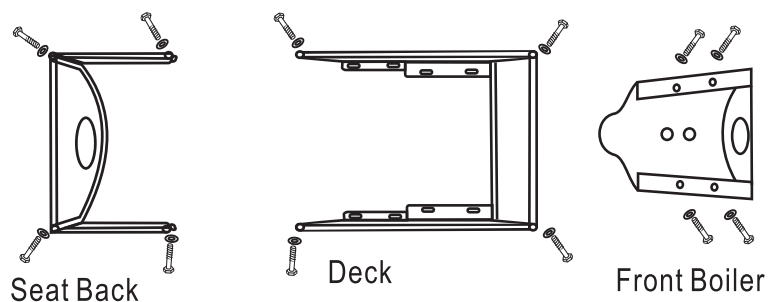

Figure 5

Step 4 (As shown at Figure 6)
Use 10 mm wrench to secure the Second Boiler and Roof onto the Deck.

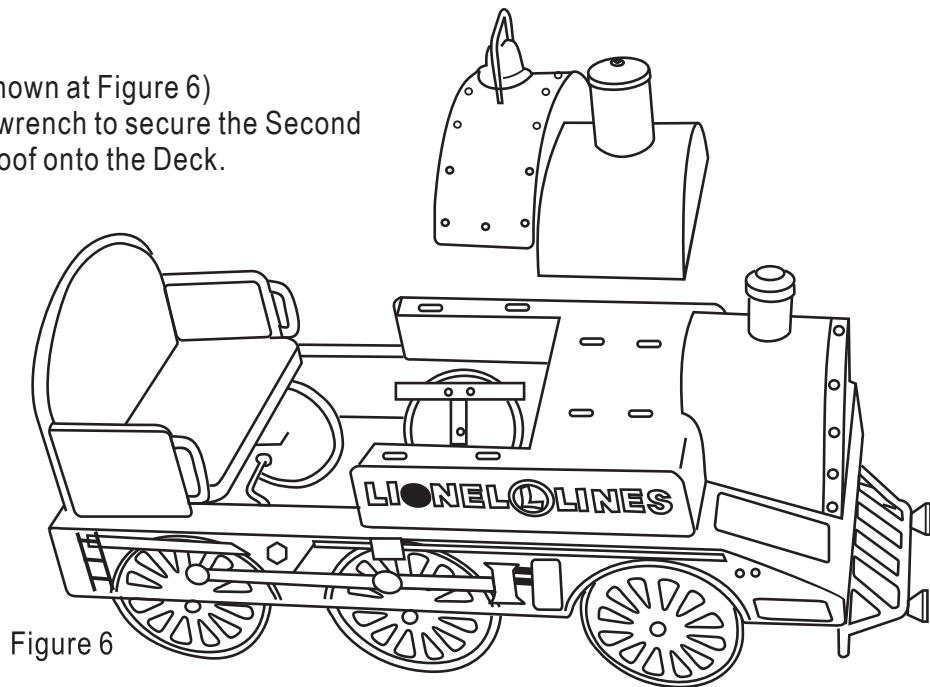

Figure 6

Step 5 (As shown at Figure 7)

- 1) Insert Steering Rod thru the Guide, and into the Steering Bar. Secure the Small Bolt and nut onto the Steering Rod.
- 2) Insert the Steering Wheel on the end of the Steering Rod, secure the Steering Wheel by the bolt and nut.
- 3) Secure the Pedals on the Drive Linkages.

Steering Wheel

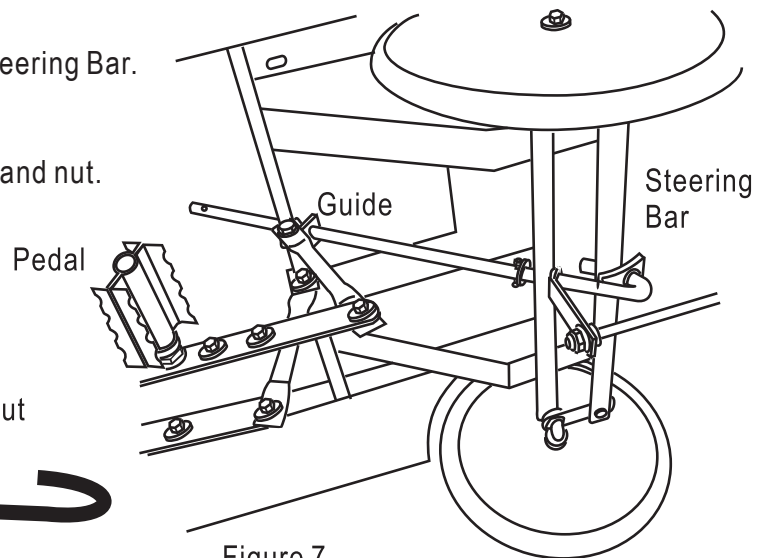
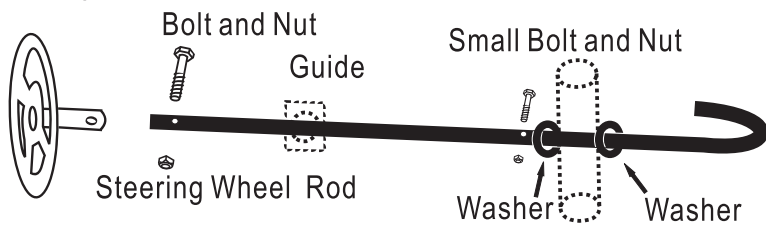

Figure 7

Step 6 (As shown at Figure 8)

- 1) Screw the Cowcatcher Support Rod onto the Cowcatcher, put Crown Nut on the end as Figure 8 and tighten.
- 2) Insert the Thin Nut on rear tip of Cowcatcher Support Rod.
- 3) Insert the Cowcatcher Support Rod onto the Train Frame.
- 4) Secure the Cowcatcher Support Rod by Lock Nut.
- 5) Screw on the 2 pairs of the Bumpers at Front and Rear of Train Frame.

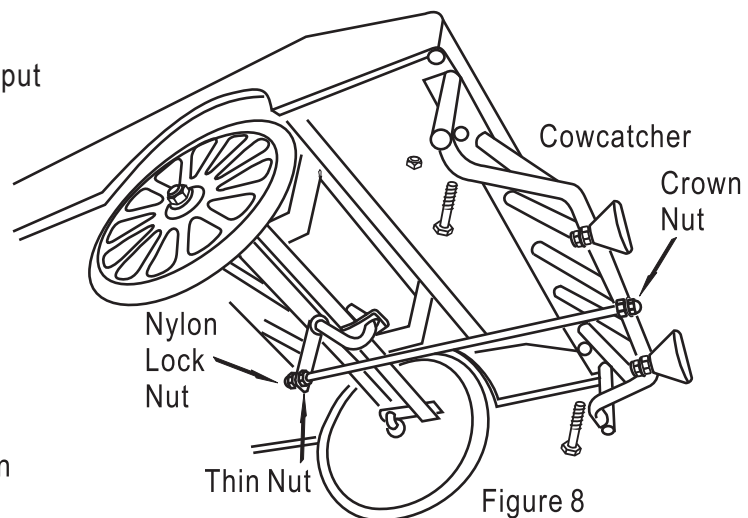
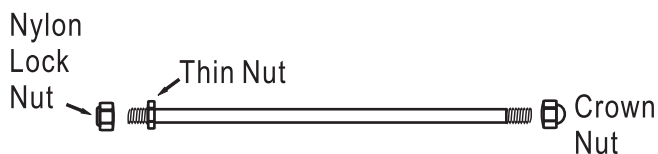

Figure 8