

## Owner's Manual

[Please keep this Owner's Manual for future reference. If you sell or give this product to someone, please include this Owner's Manual, and ask the new owners to read the instructions completely before operating.]

**PRIOR TO ASSEMBLY:**

Please read this Owner's Manual completely before assembling or operating this product. Assembly of this product should be carried out by an adult.

All parts are Wrapped in packing material to prevent damage during shipment. Remove all packing materials from the box prior to assembly. Save all packing materials until assembly is complete to make sure no parts are accidentally thrown away. After assembly is complete, properly discard all waste.

Refer to the Parts and Tools List and Diagram on this page of this manual to make sure all parts are accounted for.

Do not return this product to the store! If any parts are missing or damaged, please contact one of our Customer Service Representatives by phone at 1-973-960-2688,

**IMPORTANT SAFETY INFORMATION:**

**WARNING** Never leave your child unattended on this WHEELBARROW!

**WARNING** This WHEELBARROW does not have a brake.





**WARNING** Do not use in wet weather or when road surface is slippery!

**WARNING** Periodically re-check all fasteners to make sure they are tight!

**TOOLS REQUIRED FOR ASSEMBLY:**

Hammer, Adjustable Wrench, Screw Driver

Adult Assembly Required !

Parts List		Hardware Set Components	
Qty	Description	Qty	Description
1	Wheelbarrow Pan	2	6mm (Large Diameter) Short Bolt, Nut and Washer set. 
1	Wheel	4	6mm Medium Bolt, Nut and Washer set. 
1	Wood Handle	2	6mm Long Bolt, Nut and Washer Set 
2	Wood Handle	2	5mm (Small diameter) Bolt Nut and Washer Set 
1	L Supporter		
1	R Supporter		
1	Front Axle		
1	Connector with long bolt		
1	Hardware Set		

Your New Wheelbarrow will look like the picture of Figure 1.

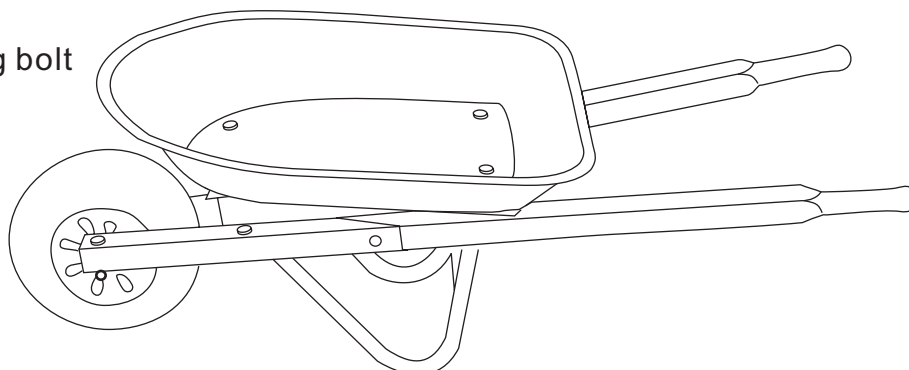

MORGAN CYCLE LLC  
Union, New Jersey 07083  
[www.morgancycle.com](http://www.morgancycle.com)

Questions? Service or Comments  
[help@morgancycle.com](mailto:help@morgancycle.com) or call 973-960-2688

Figure 1

Open carton, remove contents, and compare contents with parts list Note: To prevent scratching of the frame, it is recommended that you lay the parts out on top of a flattened cardboard box, or other soft surface.

## Assembly Instructions

4 sets of Medium 6 mm Bolt, Nut and Washer

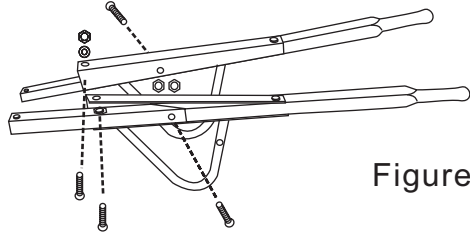

Figure 2

Step 1: Attach the Wood Handle onto the Supporter, using FOUR Medium 6mm Bolt Nut & Washer Set. Secure by wrench. As shown at Figure 2.

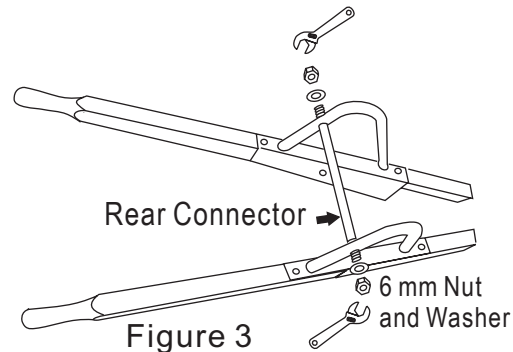

Figure 3

Step 2: Attach the Rear Connector onto the Handles and Supporter, using TWO 6mm Nut & Washer Set. Secure by wrench. As shown at Figure 3.

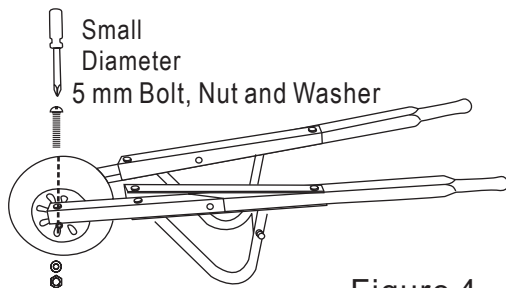

Figure 4

Step3: Attach the Front Wheel and Axle onto the Handles and Supporter, using small diameter TWO 5mm Bolt Nut & Washer Set. Secure by wrench. As shown at Figure 4.

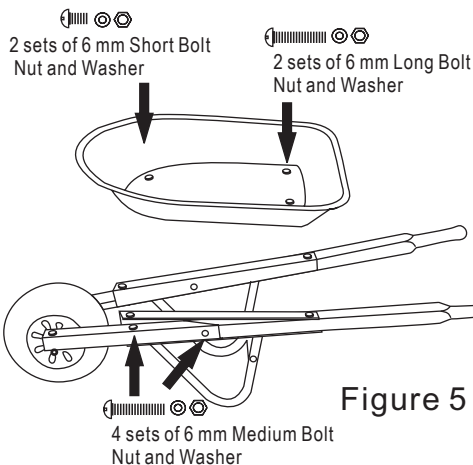

Figure 5

Step 4: Attach the Pan and Handles Supporter, using TWO 6mm Short Bolt Nut & Washer Set on front. Secure by wrench. As shown at Figure 5.

Step 5: Attach the Pan and Handles Supporter, using TWO 6mm Long Bolt Nut & Washer Set on the rear. Secure by wrench. As shown at Figure 5.

Note: Information contained in Owners Manual may be changed or updated. Please visit our website listed below: [www.morgancycle.com](http://www.morgancycle.com)

Questions? Service or Comments  
[help@morgancycle.com](mailto:help@morgancycle.com) or call 973-960-2688