

Morgan Model T Pedal Car  
OWNER'S MANUAL

[Please keep this Owner's Manual for future reference. If you sell or give this product to someone, please include this Owner's Manual, and ask the new owners to read the instructions completely before operating.]

Congratulations for choosing your new Morgan Model T Pedal Car. We have carefully constructed your Morgan Model T Pedal Car so that its safety and performance meet the highest standards. Make sure the size of the Morgan Model T Pedal Car meets your child's personal requirements and Morgan Model T Pedal Car is assembled and adjusted by an adult. With proper care and maintenance, your new Morgan Model T Pedal Car will give your child riding pleasure for years to come. Some illustrations may vary from actual Pedal Car as delivered.

**⚠ Adult assembly required!**

**PRIOR TO ASSEMBLY:**

- Please read this Owner's Manual completely before assembling or operating this product.
- Assembly of this product should be carried out by an adult.
- All parts are Wrapped in PACKING MATERIAL to prevent damage during shipment. Remove all packing materials from the box prior to assembly. Save all packing materials until assembly is complete to make sure no parts are accidentally thrown away. After assembly is complete, properly discard all waste.
- Refer to the Parts List and Diagram on page two of this manual to make sure all parts is accounted for.
- **DO NOT RETURN** this product to the store! If any parts are missing or damaged, please contact one of our Customer Service Representatives by e-mail: [help@morgancycle.com](mailto:help@morgancycle.com) or (973) 960-2688.

Tools Required For Assembly: Adjustable Wrench and 6" Screw Driver

Your Morgan Model T Pedal Car will look as the picture shown as below, Figure 1.

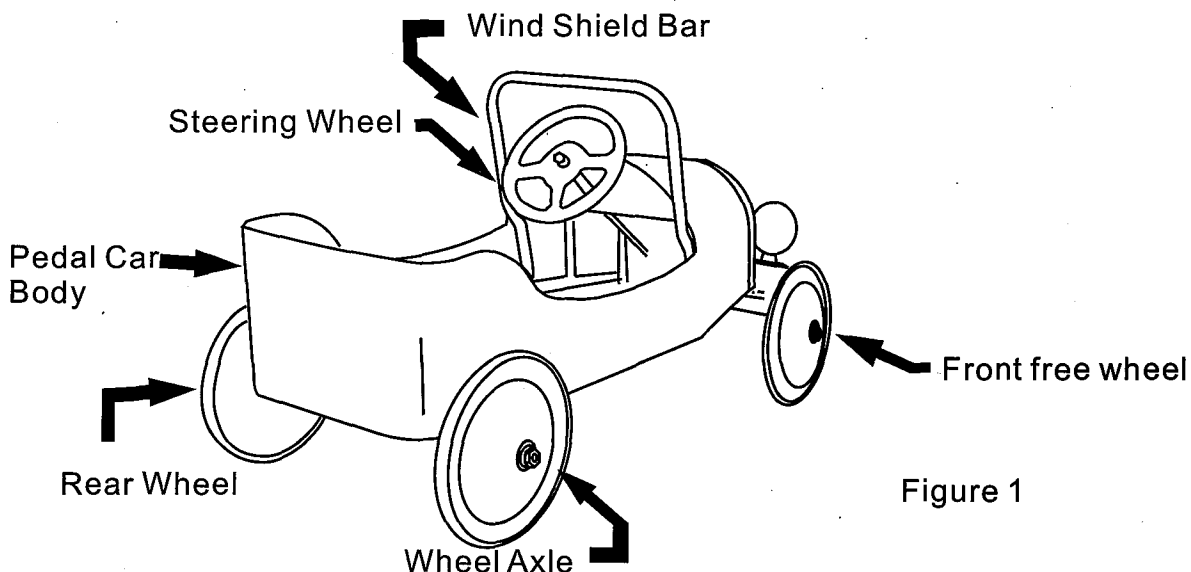
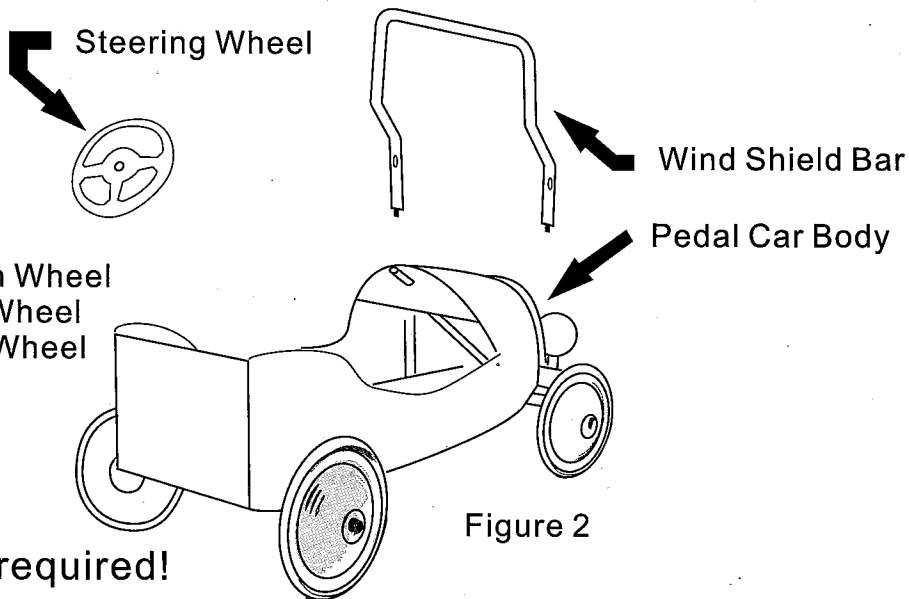

Figure 1

**Step 1** Check parts list.

## Parts List

- 1 - Car Body
- 1 - Steering Wheel
- 1 - Wind Shield Bar
- 1 - Large Rear Driven Wheel
- 1 - Large Rear Free Wheel
- 2 - Small Front Free Wheel



**⚠ Adult assembly required!**

- Step 2**
- 1) Locate the 2 small front Wheels, insert to the front axle, and tight.
  - 2) Locate the Large Rear Wheels, insert to the rear axle, and tighten the Free wheel and Driven wheel separately.
  - 3) Locate the Steering Wheel and steering wheel rod, insert the steering wheel onto the steering wheel rod, use adjustable wrench to secure the crown nut. Shown as the Figure 3.
  - 4) Insert Wheels on the axle. Tighten the nut on each axle. Shown as the Figure 2.

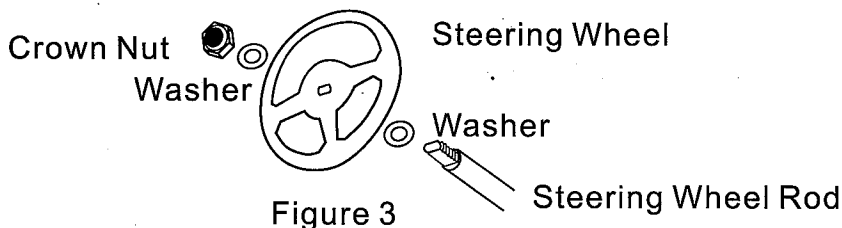

- Step 3**
- 1) Insert the tip end of the Wind Shield Bar into the Body frame.
  - 2) Locate the hole on the side panel of the body.
  - 3) Insert the Screw and tighten the nut by hand first.
  - 4) Do not tighten the screw by wrench now.
  - 5) Insert the Screw on other side, hand tighten the screw.
  - 6) Use Screw Driver and Wrench tighten bolt and nut of both side. Shown as the Figure 4.

